

FCS-KM

STIHL



2 - 17 Instruction Manual



Contents

1	KombiSystem.....	2
2	Guide to Using this Manual.....	2
3	Safety Precautions and Working Techniques.....	2
4	Using the Unit.....	6
5	Approved KombiEngines.....	8
6	Assembling the Unit.....	9
7	Mounting the KombiTool.....	10
8	Mounting the Cutting Blade.....	10
9	Starting / Stopping the Engine.....	11
10	Storing the Machine.....	11
11	Replacing the Depth Wheel.....	12
12	Replacing the Skirt.....	12
13	Replacing the Cutting Blade.....	12
14	Checking and Replacing the Wear Guard	13
15	Maintenance and Care.....	13
16	Minimize Wear and Avoid Damage.....	13
17	Main Parts.....	14
18	Specifications.....	14
19	Maintenance and Repairs.....	15
20	Disposal.....	16
21	EC Declaration of Conformity.....	16
22	UKCA Declaration of Conformity.....	16
23	Addresses.....	17

1 KombiSystem

In the STIHL KombiSystem a number of different KombiEngines and KombiTools can be combined to produce a power tool. In this instruction manual the functional unit formed by the KombiEngine **and** KombiTool is referred to as the power tool.

Therefore, the separate instruction manuals for the KombiEngine and KombiTool should be used together for the power tool.

Always read and and make sure you understand **both** instruction manuals before using your power tool for the first time and keep them in a safe place for future reference.

2 Guide to Using this Manual

2.1 Pictograms

All the pictograms attached to the machine are shown and explained in this manual.

2.2 Symbols in text

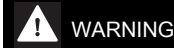

WARNING

Warning where there is a risk of an accident or personal injury or serious damage to property.

NOTICE

Caution where there is a risk of damaging the machine or its individual components.

2.3 Engineering improvements

STIHL's philosophy is to continually improve all of its products. For this reason we may modify the design, engineering and appearance of our products periodically.

Therefore, some changes, modifications and improvements may not be covered in this manual.

3 Safety Precautions and Working Techniques



Special safety precautions must be observed when working with this edger because it has a sharp cutting blade that rotates at very high speed.



Read both User Manuals (KombiEngines and KombiTools) carefully before using the unit for the first time and keep them in a safe place for future reference. Non-compliance with the User Manuals may cause serious or even fatal injury.

The power tool should only be provided or loaned to people familiar with this model and its operation. The User Manuals for KombiEngines and KombiTools should always be handed over with the machine.

The edger may only be used to cut borders along paths, flower beds and lawns.

The machine must not be used for any other purposes – **risk of accident!**

Only use blades or accessories which have been approved by STIHL for this machine or which are technically equivalent. If you have any questions about this, consult your dealer.

Use only high-quality parts and accessories. In order to avoid the risk of accidents and damage to the machine.

STIHL recommends the use of genuine STIHL tools and accessories. They are specifically

designed to match the product and meet the requirements of the user.

The deflector provided with the edger may not protect the operator from all foreign objects (gravel, glass, wire etc.) thrown by the revolving blades. Ejected objects may also ricochet and strike the operator.

Never attempt to modify your power tool in any way since this may increase the risk of personal injury. STIHL excludes all liability for personal injury and damage to property caused while using unauthorized attachments.

Do not use a high-pressure washer to clean the power tool. The solid jet of water may damage parts of the unit.

3.1 Clothing and Equipment

Wear proper protective clothing and equipment.



Clothing must be sturdy but allow complete freedom of movement. Wear close-fitting clothes such as a boiler suit, not a loose jacket.

Do not wear clothing which could become trapped in wood, brush or moving parts of the machine. Do not wear a scarf, necktie or jewelry. Tie up and secure long hair above your shoulders.



Wear safety boots with steel toe caps and non-slip soles.



WARNING



To reduce the risk of eye injuries, wear close-fitting safety glasses in accordance with European Standard EN 166 (for Canada, in accordance with standard CSA Z94). Make sure the safety glasses fit snugly.

Wear "personal" sound protection, e.g. ear defenders.

Wear face protection and make sure it fits well. Face protection alone is not sufficient to protect the eyes.



Wear sturdy protective gloves made of a resistant material (e.g. leather).

STIHL offers a comprehensive range of personal protective equipment.

3.2 Transporting the machine

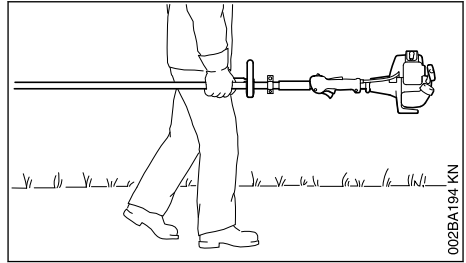

002BA194 KN

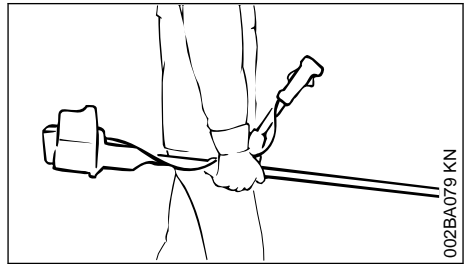

002BA079 KN

Always stop the engine.

Carry the machine by the shaft so that it is balanced - the cutting attachment should face forwards.

Do not touch hot parts of the machine – **risk of burn injury!**

By vehicle: When transporting in a vehicle, properly secure your machine to prevent turnover, damage and fuel spillage.

3.3 Before starting

Check that your power tool is in safe operating condition – refer to appropriate chapters in the User Manuals for KombiEngines and Kombi-Tools:

- Blades: correctly and securely mounted and in good condition (clean, move freely, not warped)
- Inspect the deflectors for damage and wear. Do not use the machine with a damaged deflector – replace damaged parts
- Do not attempt to modify the controls or safety devices in any way – only work with the deflector fitted
- Keep the handles dry and clean – free from oil and dirt – this is important for safe control of the machine.
- Adjust the harness and handle(s) to suit your height and reach.

The power tool must only be operated when it is in good operating condition – **Risk of accident!**

To prepare for emergencies when using a harness: Practice setting down the machine quickly. To avoid damage, do not throw the unit to the ground when practicing.

3.4 Holding and Guiding the Tool

Make sure you always have a firm and secure footing.

Always hold the power tool firmly with both hands on the handles.

3.4.1 For versions with loop handle

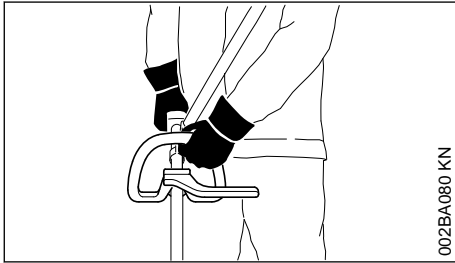

For versions with loop handle and loop handle with barrier bar, left hand on the loop handle, right hand on the control handle – even if you are left-handed.

3.4.2 For versions with bike handle

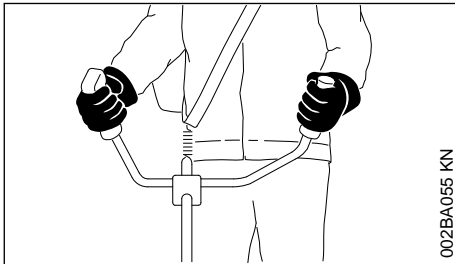

Right hand on control handle, left hand on grip on handlebar.

3.5 While Working

In the event of impending danger or in an emergency, switch off the engine immediately by moving the slide control / stop switch/button to **0** or **STOP**.

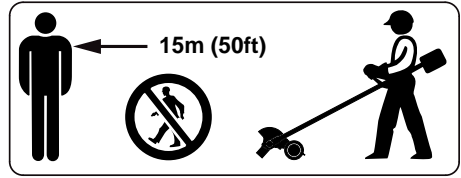

There is a risk of accident from ejected objects within a wide area around the working space, so you must ensure that there is no-one within a 15 m radius of the machine. This distance must also be maintained in relation to objects (vehicles, window panes) – **risk of property damage!** Even at distances beyond 15 m, the danger cannot be ruled out.



Avoid contact with the blade – **risk of injury!**

Check for correct idling, so that the blade stops moving when the throttle trigger is released. Check and correct the idle speed setting at regular intervals. If the blade still rotates when the engine is idling, have a dealer repair the machine – see User Manual for KombiEngines.



Never work without deflector suitable for the respective machine and cutting tool – **risk of injury** from ejected objects!



The gear head becomes hot during operation. Do not touch the gear housing – **risk of burns!**

Take special care in **slippery conditions** – damp, snow, ice, on slopes or uneven ground!

Watch out for obstacles: Tree stumps, roots – **risk of tripping or stumbling!**



Check the work site – rocks, metal objects etc. could get caught up and ejected – potentially beyond a distance of 15 m – **risk of injury!** Such objects can also damage the cutting attachment and other property (e.g. parked vehicles, windows).



Do not work in the area above or directly below the ground surface where cables or cords have been laid – **risk of electrical shock!** Touching and damaging these lines with KombiTools could cause serious or even **fatal injury**.

Make sure you always have a firm and secure footing.

Be particularly careful when working on difficult, densely grown terrain.

Be particularly alert and cautious when wearing ear protection because your ability to hear warnings (shouts, alarms, etc.) is impaired.

Take breaks when you start getting tired or feeling fatigue – **risk of accidents!**

Work calmly and carefully – in daylight conditions and only when visibility is good. Proceed with caution, do not put others in danger.

Never touch the blade when the motor is running. If the blade becomes jammed by an object, switch off the engine immediately before attempting to remove the object – **risk of injury!**

Blockage of the blade while at the same time opening the throttle increases the load and reduces the working speed of the engine. The constant slipping of the clutch causes overheating and damage to important components (e.g. clutch, plastic housing parts) – for example, subsequently to the blade moving during idling – **risk of injury!**

If your power tool is subjected to unusually high loads for which it was not designed (e.g. heavy impact or a fall), always check that it is in good condition before continuing work – see also "Before Starting". Make sure the safety devices are working properly. Never use a power tool that is no longer safe to operate. In case of doubt, contact a dealer.

Examine the blade periodically at short intervals and as soon as you note any noticeable changes:

- Turn off the engine, hold the edger securely and press the blade against the lawn to stop it
- Check condition and secure fitting; watch out for cracks
- A defective blade must be replaced immediately, even if there are only minor hairline cracks.

Clean the area around the cutting attachment and deflector regularly while working.

- Shut off the engine
- Use gloves
- Remove grass, weeds, clumps of soil, etc.

To reduce the risk of injury, shut off the engine before replacing the cutting attachment.

Do not reuse or repair damaged or cracked blades – for example, by welding or straightening – risk of deformation (out-of-balance).

Particles or pieces may come off and hit the operator or a bystander at a high speed – **risk of most severe injuries!**

If a rotating metal cutting attachment touches a rock or another hard object, sparks may be generated which may possibly ignite combustible materials. Dried-out plants and undergrowth are combustible, especially in hot and dry weather. If there is a risk of fire, do not use metal cutting attachments in the vicinity of combustible materials, dried-out plants or brushwood. It is mandatory that you ask the responsible forestry office about current fire hazards.

3.6 After Finishing Work

After finishing work or before leaving the power tool unattended: Shut off the engine.

Clean the cutting attachment regularly after finishing work to remove dust, dirt, soil and plant debris – wear gloves – **risk of injury!**

Do not use any grease solvents when cleaning.

After cleaning it thoroughly, coat the surface of metal cutting attachments with a corrosion-proofing agent.

3.7 Maintenance and Repairs

Service the machine regularly. Do not attempt any maintenance or repair work not described in the KombiTool and KombiEngine instruction manuals. Have all other work performed by a servicing dealer.

STIHL recommends that you have servicing and repair work carried out exclusively by an authorized STIHL servicing dealer. STIHL dealers are regularly given the opportunity to attend training courses and are supplied with the necessary technical information.

Only use high-quality replacement parts in order to avoid the risk of accidents and damage to the machine. If you have any questions in this respect, consult a servicing dealer.

STIHL recommends the use of genuine STIHL replacement parts. They are specifically designed to match your model and meet your performance requirements.

To reduce the risk of injury, **always shut off the engine** before carrying out any maintenance or repairs or cleaning the machine.

3.8 Cutting Attachments and Deflectors

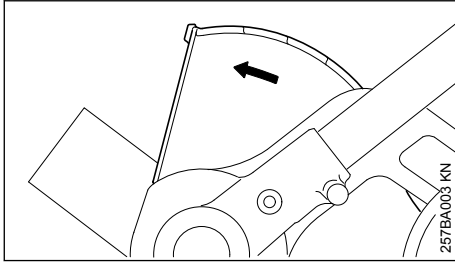

The arrow on the deflector shows the direction of rotation of the blade – see "Using the Unit".

Operate the edger only with the skirt properly mounted on the deflector – see "Replacing the Skirt".

Handle the blade with care – see "Using the Unit".

Best cutting results: At full throttle working at a steady pace.

STIHL recommends you use only original STIHL cutting blades – see "Special Accessories". Only use deflectors or accessories that are explicitly approved for this power tool by STIHL or are technically identical.

4 Using the Unit

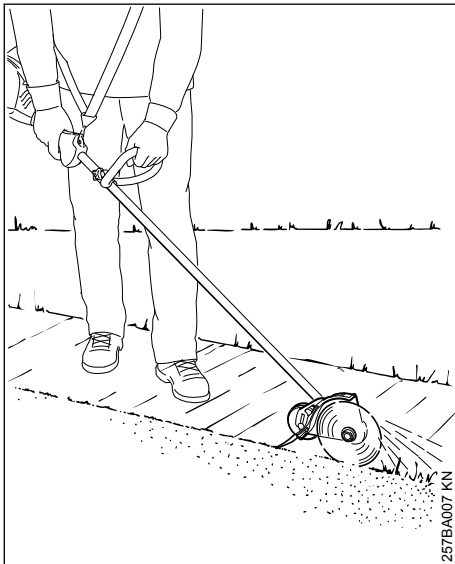

Your power edger is designed to produce sharp contoured borders around lawns and flower beds. It will cut almost all types of grass, weeds and soft green plants.

4.1 Preparations

If the work area is very dry, spray it lightly with water: this softens the soil and ensures that less dust is created. Slightly damp green plants are easier to cut.



Clear away all obstacles and solid objects from the work area.

- ▶ Plan the best route for edging. Always hold and operate your edger on the right-hand side of your body.

4.2 Adjusting Depth of Cut

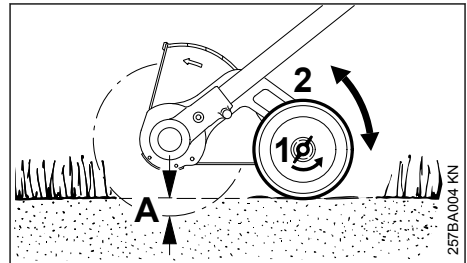

- ▶ Shut down the engine.
- ▶ Loosen the wingnut (1) counterclockwise.
- ▶ Push wheel (2) upwards to increase the depth of cut (A) or downwards to reduce the depth of cut (A).

4.2.1 Adjust correctly

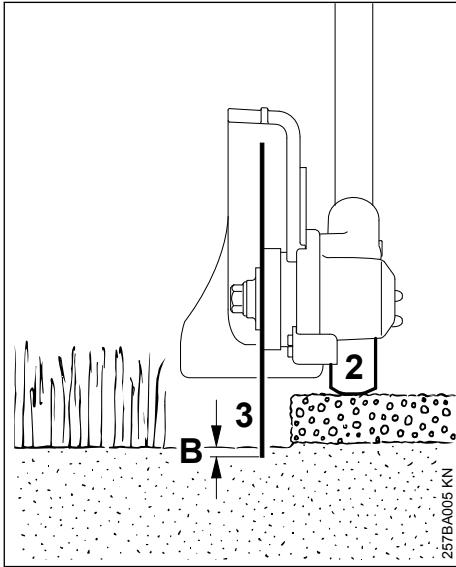

The depth of cut depends on the unevenness of the ground, your height and the way you hold the edge. Use the following procedure:

- ▶ Adjust the depth wheel (2) so that the blade (3) just touches the ground or breaks the surface of the soil (B) by no more than 5 mm (0.2 in).

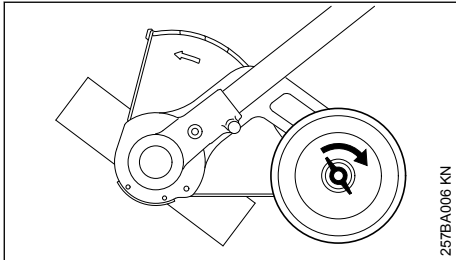

- ▶ Tighten down the wingnut clockwise.
- ▶ Standing in the normal working position, check the depth of cut again and correct it if necessary.

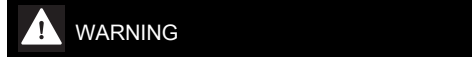
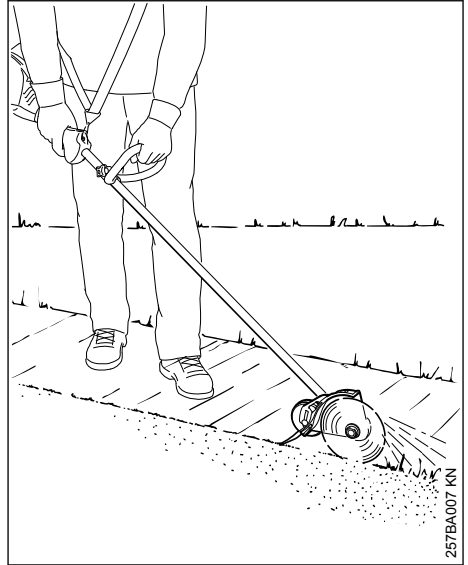

Do not adjust the deflector.

The deflector has been set at the factory so that the arrow on the deflector and the open side point away from the operator. This ensures that cuttings and other debris are directed away from the power tool and operator.

4.3 Edging

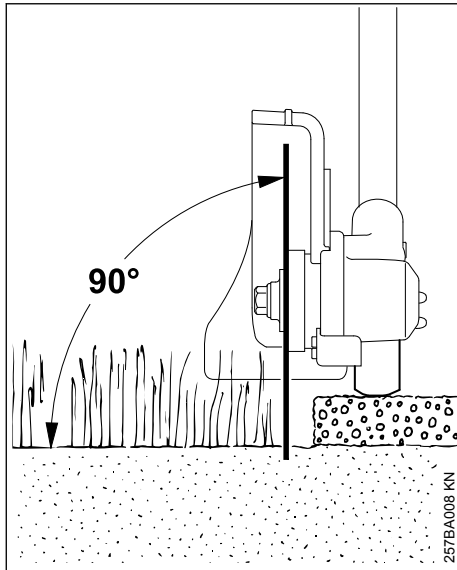

- ▶ Start the engine
- ▶ Start the cut at no less than half throttle and continue cutting at full throttle.
- ▶ Hold and guide your power tool so that the blade is vertical.
- ▶ Cut steadily so that the engine is not lugged down – do not apply force.
- ▶ Operate at no more than a normal walking pace.
- ▶ Do not push the blade into the ground.
- ▶ Always walk forwards when cutting, do not pull the unit towards you.
- ▶ Cut at a steady pace to avoid having to make several passes.

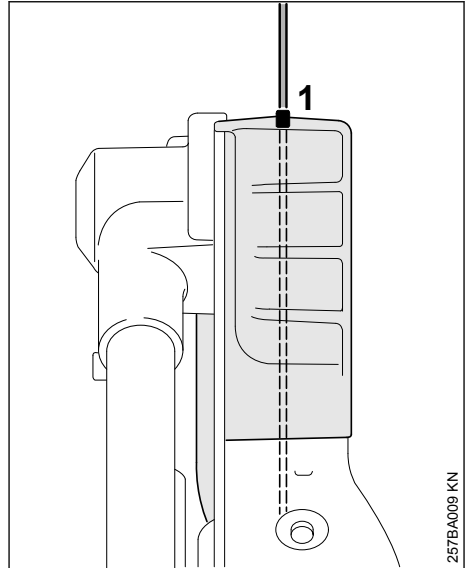

- ▶ Use the gunning sight (1) to line the blade up with the edge of the bed.

5 Approved KombiEngines

5.1 KombiEngines

Only use KombiEngines supplied or explicitly approved by STIHL for use with the attachment.

This KombiTool may be operated only with the following KombiEngines:

STIHL KM 55 R, KM 56 R, KM 85 R, KM 90, KM 90 R, KM 94 R¹⁾, KM 100, KM 100 R, KM 110, KM 110 R, KM 130, KM 130 R, KMA 130 R, KMA 135 R; KMA 80.0 R, KMA 120.0 R, KMA 200.0 R



Machines with a loop handle must be equipped with a barrier bar.

5.2 Brushcutters with split boom

The KombiTool can also be mounted on STIHL brushcutters with a split shaft (T-models) (basic power tools).

This KombiTool can therefore also be used on the following machine:

¹⁾ When using the FCS-KM together with the KM 94 R, the rigid shaft in the FCS-KM must be replaced by a flexible shaft.

STIHL FR 130 T

**WARNING**

Refer to the power tool's User Manual for how to use the barrier bar.

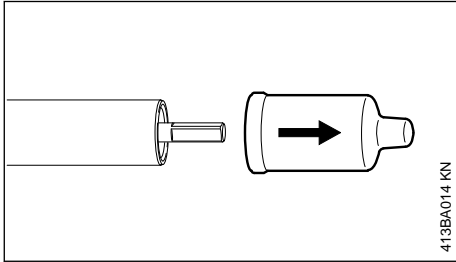
6 Assembling the Unit

413BA014 KN

- ▶ Pull the protective caps off the ends of the drive tube and keep them in a safe place for later use – see "Storing the Machine".

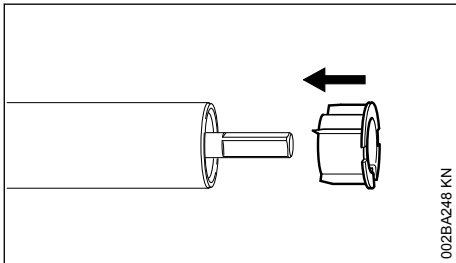

002BA248 KN

NOTICE

The plug may come out of the drive tube when you pull off the cap. Push it back into the drive tube as far as stop.

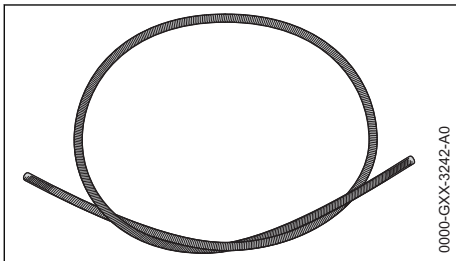
6.1 Installing the Flexible Shaft

0000-GXX-3242-A0

If the FCS-KM KombiTool is used with a KM 94 R KombiMotor, its rigid shaft must be removed and the flexible shaft installed in its place. The

flexible shaft is not included with the machine. It is available from a STIHL servicing dealer.

The rigid shaft must be re-installed if the FCS-KM is used with a KombiMotor other than the KM 94 R.

- ▶ If the gearbox is still mounted on the shaft: Remove the gearbox.

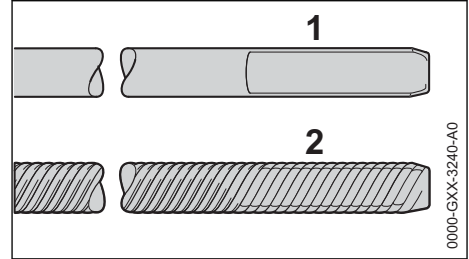

0000-GXX-3240-A0

- ▶ Pull the rigid shaft (1) out of the drive tube.
- ▶ Lubricate the flexible shaft (2) with STIHL multipurpose grease or gear lubricant.

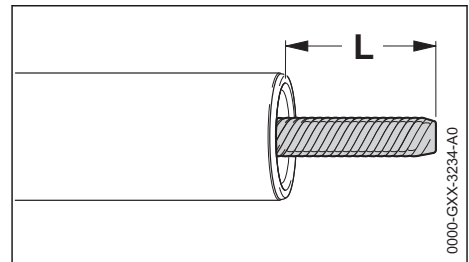

0000-GXX-3234-A0

- ▶ Push the flexible shaft into the drive tube.

The drive shaft must not project from the tube more than 22 mm (L).

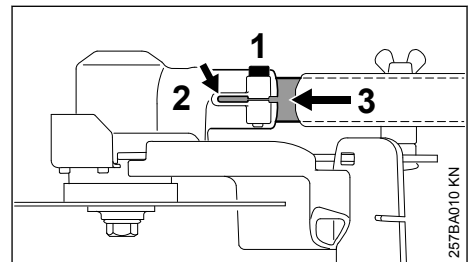
6.2 Mounting the Gearbox

257BA010 KN

- ▶ Loosen the clamp screw (1) on the gearbox (2).
- ▶ Push the drive tube (3) through the clamp and into the gearbox – turn the gearbox back and forth as necessary.

- ▶ Once the end of the drive tube is inserted beyond the slot (see arrow) in the clamp (5), push it fully home as far as stop.
- ▶ Tighten down the clamp screw as far as stop.

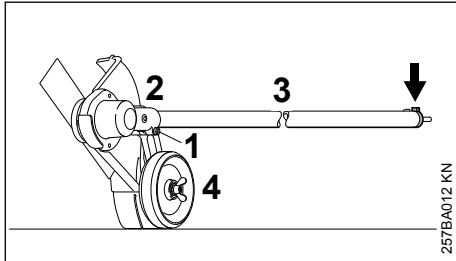

- ▶ Line up the gearbox (2) on the drive tube (3) so that the lug (arrow) points vertically upwards when the depth wheel (4) is vertical.
- ▶ Tighten down the clamp screw (1) firmly.

7 Mounting the KombiTool

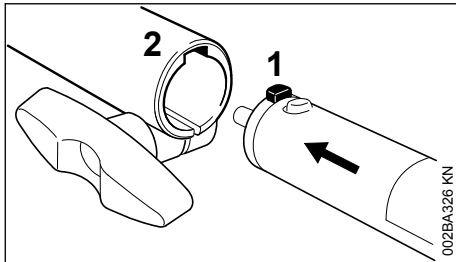

- ▶ Push the lug (1) on the drive tube into the slot (2) in the coupling sleeve as far as stop.

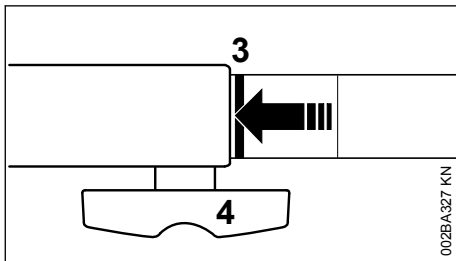

When correctly installed, the red line (3) (arrow point) must be flush with the end of the coupling sleeve.

- ▶ Tighten down the star knob (4) **firmly**.

7.1 Removing the KombiTool

- ▶ Reverse the above sequence to remove the drive tube.

8 Mounting the Cutting Blade

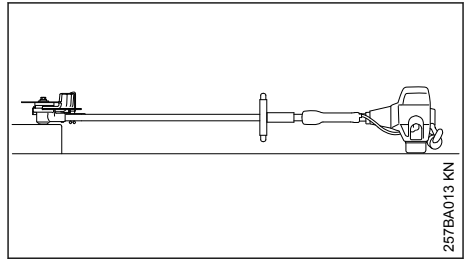

- ▶ Lay the power edge on its back so that the blade mounting (1) faces up.

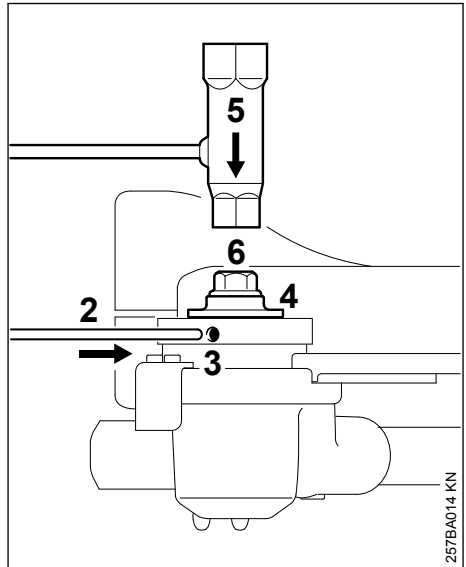

- ▶ Insert the stop pin (2) into the hole (3) as far as stop – apply slight pressure and turn back and forth together with the thrust plate (4) until the pin slips into position and blocks the shaft.
- ▶ Fit the combination wrench (5) on the screw (6).
- ▶ Loosen the screw clockwise (left-hand thread) and take it out.

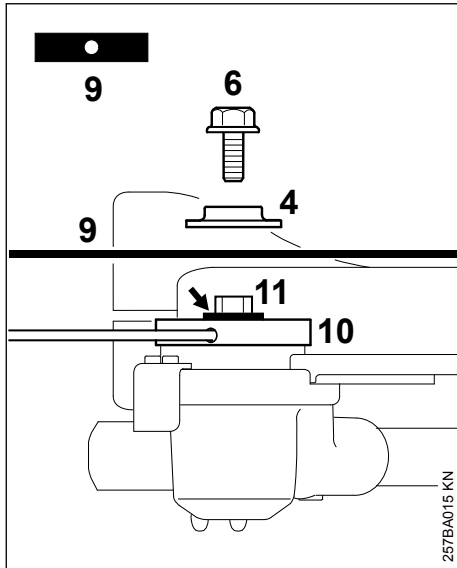

- ▶ Remove the thrust washer (4).
- ▶ Position the blade (9) on the thrust plate (10).

! WARNING

Collar (see arrow) must engage the blade's mounting hole.

- ▶ Fit the thrust washer on the shaft (11) and block the shaft.
- ▶ Fit the screw (6) in the shaft counterclockwise and tighten it down firmly.

9 Starting / Stopping the Engine

9.1 Starting the engine

To start the engine, basically follow the instructions for use for the KombiEngine or basic power tool!

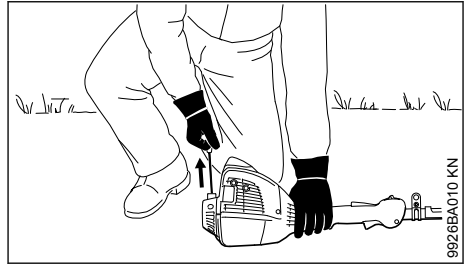
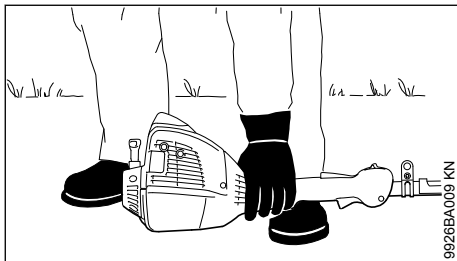

- ▶ Place the machine on the ground in a secure position

The blade must not touch the ground or any other objects – **risk of accident!**

- ▶ Assume a firm stance – possibilities: standing, bending or kneeling
- ▶ Press the machine **firmly** against the ground with the left hand – do not touch the control elements on the control handle while doing so – see instruction manual for the KombiEngine or basic power tool

NOTICE

Do not stand or kneel on the shaft!

! WARNING

If the engine is started, the blade may rotate as soon as the engine is running – therefore blip the throttle trigger as soon as the engine is running – the engine begins to idle.

The other starting procedure is described in the instruction manual for the KombiEngine or basic power tool.

9.2 Switching off the engine

- ▶ see instruction manual for the KombiEngine or basic power tool

10 Storing the Machine

For periods of 30 days or longer

- ▶ Remove, clean and inspect the cutting blade.
- ▶ If the KombiTool is removed from the KombiEngine and stored separately: Fit the protective cap on the drive tube to avoid dirt getting into the coupling.
- ▶ Store the machine in a dry, high or locked location – out of the reach of children and other unauthorized persons.

11 Replacing the Depth Wheel

Have a worn depth wheel replaced by a servicing dealer. STIHL recommends that you have servicing and repair work carried out exclusively by an authorized STIHL servicing dealer.

11.1 Depth Wheel

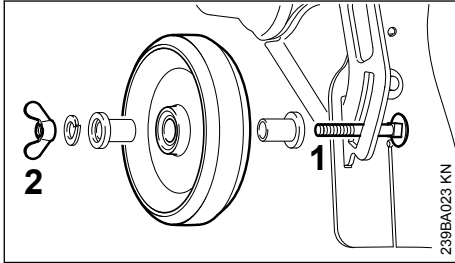

- ▶ The end of the thread on the screw (1) is peened over to ensure that the wingnut (2) does not work loose and be lost.

A very high torque has to be applied to remove the wingnut from the screw. If the parts are then reassembled, the captive function is no longer guaranteed. In such a case have the screw and wingnut replaced by a servicing dealer.

12 Replacing the Skirt

12.1 Removing the skirt

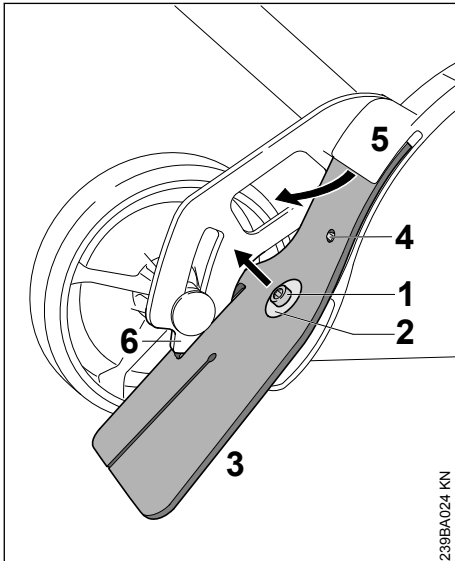

- ▶ Undo and remove the screw (1).
- ▶ Remove the washer (2)

- ▶ Pull the skirt (3) out of the segment (6) and out of the gap (5) in the deflector

12.2 Fitting the skirt

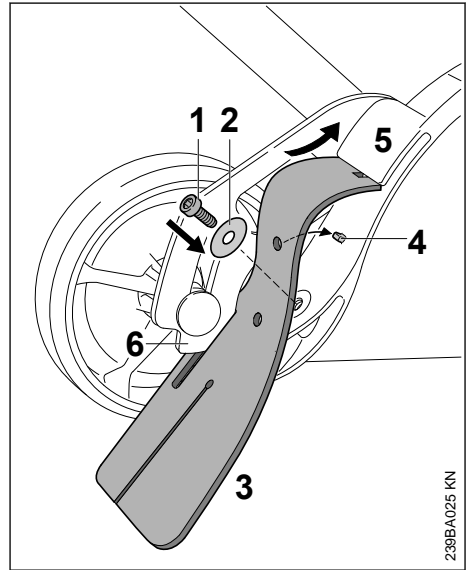

- ▶ In order to push the skirt easily into the gap on the deflector, apply a thin coating of resin-free oil to the top of the skirt
- ▶ Thread the skirt (3) into the segment (6) and push into the gap (5) of the deflector – the bore in the skirt must be fixed in the arbor (4)
- ▶ Place washer (2) onto screw (1).
- ▶ Insert and tighten the screw (1)

13 Replacing the Cutting Blade

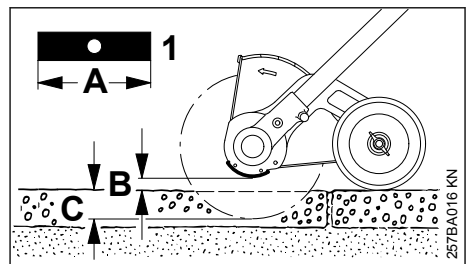

Do not attempt to straighten or weld a bent or cracked blade – **it may break** – it must be replaced – see "Mounting the Cutting Blade".

STIHL recommends you use only the following original STIHL cutting blades:

Length	Thickness	Marking
200 mm	2.4 mm	4133 / 01
200 mm	3.8 mm	4133 / 02

Do not sharpen the blade.

- ▶ Replace the blade (1) if its length (A) is no longer sufficient to maintain the necessary ground clearance (B) and obtain the required depth of cut (C).

13.1 Checking Out-of-Balance

To avoid out-of-balance:

- ▶ Have your dealer check the blade for out-of-balance on a STIHL balancer (special accessory) – STIHL recommends an authorized STIHL servicing dealer. If blade is out-of-balance, fit a new one – see "Mounting the Cutting Blade".

14 Checking and Replacing the Wear Guard

14.1 Checking the Wear Guard

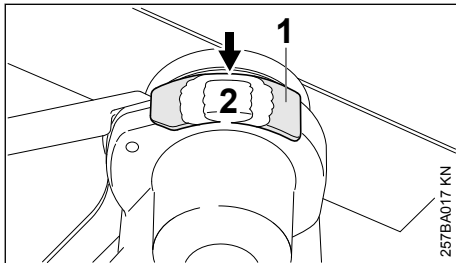

- ▶ Check the wear guard (1) for damage before starting the power tool.
- ▶ The wear guard must be replaced as soon as the gearbox (2) (arrow) becomes visible.

NOTICE

The gearbox may be seriously damaged if you do not replace the wear guard in good time.

14.2 Replacing the Wear Guard

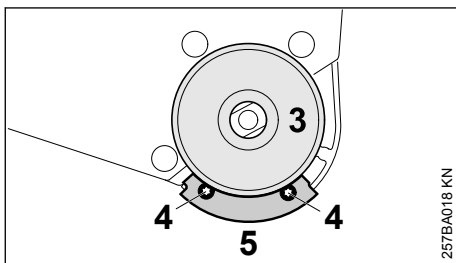

- ▶ Remove the cutting blade - see "Mounting the Cutting Blade".
- ▶ Remove the thrust plate (3).
- ▶ Take out the screws (4).
- ▶ Fit the new wear guard (5).
- ▶ Insert the screws (4) and tighten them down firmly.
- ▶ Fit the thrust plate (3).
- ▶ Mount the cutting blade - see "Mounting the Cutting Blade".

15 Maintenance and Care

The following intervals apply to normal operating conditions only. If your daily working time is longer or operating conditions are difficult (very dusty work area, etc.), shorten the specified intervals accordingly.

Accessible screws and nuts (not wingnut for depth wheel)

- ▶ Check and retighten if necessary

Depth wheel

- ▶ Visual inspection before starting work
- ▶ Check tightness of wingnut before starting work
- ▶ Have replaced if necessary – see "Replacing Wheels"

Skirt

- ▶ Visual inspection before starting work
- ▶ Replace if damaged – see "Replacing the Skirt"

Blade

- ▶ Visual inspection before starting work
- ▶ Check tightness before starting work
- ▶ Have checked for out-of-balance if necessary, replace if out-of-balance – see "Replacing the Cutting Blade"
- ▶ Replace if damaged – see "Replacing the Cutting Blade"

Wear guard

- ▶ Check before starting work
- ▶ Replace if necessary – see "Checking and Replacing the Wear Guard"

Safety labels

- ▶ Replace illegible safety labels

16 Minimize Wear and Avoid Damage

Observing the instructions in this manual and the KombiEngine manual helps reduce the risk of unnecessary wear and damage to the power tool.

The power tool must be operated, maintained and stored with the due care and attention described in these instruction manuals.

The user is responsible for all damage caused by non-observance of the safety precautions, operating and maintenance instructions. This includes in particular:

- Alterations or modifications to the product not approved by STIHL.
- Using tools or accessories which are neither approved or suitable for the product or are of a poor quality.
- Using the product for purposes for which it was not designed.
- Using the product for sports or competitive events.
- Consequential damage caused by continuing to use the product with defective components.

16.1 Maintenance Work

All the operations described in the chapter on "Maintenance and Care" must be performed on a regular basis. If these maintenance operations cannot be performed by the owner, they should be performed by a servicing dealer.

STIHL recommends that you have servicing and repair work carried out exclusively by an authorized STIHL servicing dealer. STIHL dealers are regularly given the opportunity to attend training courses and are supplied with the necessary technical information.

If these maintenance operations are not carried out as specified, the user assumes responsibility for any damage that may occur. Among other parts, this includes:

- Corrosion and other consequential damage resulting from improper storage.
- Damage to the product resulting from the use of poor quality replacement parts.

16.2 Parts Subject to Wear and Tear

Some parts of the power tool are subject to normal wear and tear even during regular operation in accordance with instructions and, depending on the type and duration of use, have to be replaced in good time. Among other parts, this includes:

- Blades (all types)
- Mounting hardware for blade
- Deflector, skirt
- Wear guards

17 Main Parts

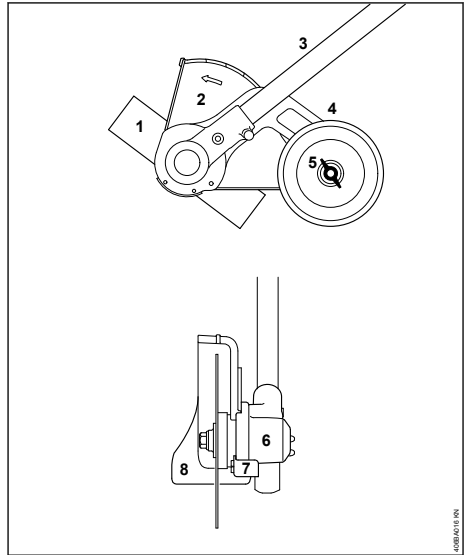

- 1 Blade
- 2 Deflector
- 3 Drive tube
- 4 Depth wheel
- 5 Wingnut
- 6 Gearbox
- 7 Wear guard
- 8 Skirt

18 Specifications

18.1 Engine speed

Max. output shaft speed on cutting attachment with KombiEngine:

KM 55 R:	4550 rpm
KM 56 R:	4800 rpm
KM 85 R:	5050 rpm
KM 90 R:	4900 rpm
KM 94 R:	4900 rpm
KM 100 R:	4900 rpm
KM 110 R:	4900 rpm
KM 130 R:	4900 rpm
KMA 130 R:	4100 rpm
KMA 135 R:	4100 rpm
KMA 80.0 R:	4100 rpm
KMA 120.0 R:	4100 rpm
KMA 200.0 R:	rpm

Max. output shaft speed (cutting attachment) on STIHL brushcutters with split shaft (T models):

FR 130 T: 4900 rpm

18.2 Weight

with deflector and blade: 2.4 kg

18.3 Noise and vibration values

Sound and vibration data measurements on power tools with the FCS-KM KombiTool include idling and rated maximum speed with the same duration of exposure.

For further details on compliance with Vibration Directive 2002/44/EC, see

www.stihl.com/vib

18.3.1 Sound pressure level L_{peq} in accordance with ISO 11201

KM 55 R with loop handle:	93 dB(A)
KM 56 R with loop handle:	93 dB(A)
KM 85 R with loop handle:	96 dB(A)
KM 90 R with loop handle:	90 dB(A)
KM 100 R with loop handle:	90 dB(A)
KM 130 with bike handle:	95 dB(A)
KM 130 R with loop handle:	95 dB(A)
KM 130 R with loop handle:	78 dB(A)
KM 135 R with loop handle:	77.5 dB(A)
KMA 80.0 R with loop handle:	76 dB(A)
KMA 120.0 R with loop handle:	76 dB(A)
KMA 200.0 R with loop handle:	75 dB(A)
FR 130 T:	93 dB(A)

18.3.2 Sound pressure level L_{peq} in accordance with ISO 11789

KM 94 R with loop handle: 92 dB(A)

18.3.3 Sound power level L_{weq} to ISO 3744

KM 55 R with loop handle:	102 dB(A)
KM 56 R with loop handle:	103 dB(A)
KM 85 R with loop handle:	107 dB(A)
KM 90 R with loop handle:	101 dB(A)
KM 100 R with loop handle:	101 dB(A)
KM 130 with bike handle:	105 dB(A)
KM 130 R with loop handle:	105 dB(A)
KM 130 R with loop handle:	90 dB(A)
KM 135 R with loop handle:	94 dB(A)
KMA 80.0 R with loop handle:	91 dB(A)
KMA 120.0 R with loop handle:	91 dB(A)
KMA 200.0 R with loop handle:	91 dB(A)
FR 130 T:	105 dB(A)

18.3.4 Sound power level L_{weq} in accordance with ISO 11789

KM 94 R with loop handle: 104 dB(A)

18.3.5 Vibration value $a_{hv,eq}$ in accordance with ISO 11789

	Handle, left	Handle, right
KM 55 R with loop handle:	5.3 m/s ²	6.8 m/s ²

	Handle, left	Handle, right
KM 56 R with loop handle:	5.0 m/s ²	6.4 m/s ²
KM 85 R with loop handle:	3.0 m/s ²	4.9 m/s ²
KM 90 R with loop handle:	3.4 m/s ²	4.1 m/s ²
KM 100 R with loop handle:	3.1 m/s ²	4.8 m/s ²
KM 130 with bike handle:	4.2 m/s ²	3.5 m/s ²
KM 130 R with loop handle:	6.1 m/s ²	6.8 m/s ²
FR 130 T:	1.3 m/s ²	1.7 m/s ²

18.3.6 Vibration level $a_{hv,eq}$ in accordance with ISO 22867

	Handle, left	Handle, right
KM 94 R with loop handle:	4.1 m/s ²	4.2 m/s ²

18.3.7 Vibration level $a_{hv,eq}$ according to EN 20643

	Handle, left	Handle, right
KM 130 R with loop handle:	2.0 m/s ²	1.5 m/s ²
KM 135 R with loop handle:	1.6 m/s ²	1.9 m/s ²
KMA 80.0 R with loop handle:	2.9 m/s ²	1.9 m/s ²
KMA 120.0 R with loop handle:	2.6 m/s ²	1.9 m/s ²
KM 200 R with loop handle:	3.0 m/s ²	2.8 m/s ²

The K-factor in accordance with Directive 2006/42/EC is 2.0 dB(A) for the sound pressure level and sound power level; the K-factor in accordance with Directive 2006/42/EC is 2.0 m/s² for the vibration level.

18.4 REACH

REACH is an EC regulation and stands for the Registration, Evaluation, Authorization and Restriction of Chemical substances.

For information on compliance with the REACH regulation (EC) No. 1907/2006 see

www.stihl.com/reach

19 Maintenance and Repairs

Users of this machine may only carry out the maintenance and service work described in this user manual. All other repairs must be carried out by a servicing dealer.

STIHL recommends that you have servicing and repair work carried out exclusively by an authorized STIHL servicing dealer. STIHL dealers are regularly given the opportunity to attend training courses and are supplied with the necessary technical information.

When repairing the machine, only use replacement parts which have been approved by STIHL for this power tool or are technically identical. Only use high-quality replacement parts in order to avoid the risk of accidents and damage to the machine.

STIHL recommends the use of original STIHL replacement parts.

Original STIHL parts can be identified by the STIHL part number, the **STIHL** logo and the STIHL parts symbol  (the symbol may appear alone on small parts).

20 Disposal

Contact the local authorities or your STIHL servicing dealer for information on disposal.

Improper disposal can be harmful to health and pollute the environment.

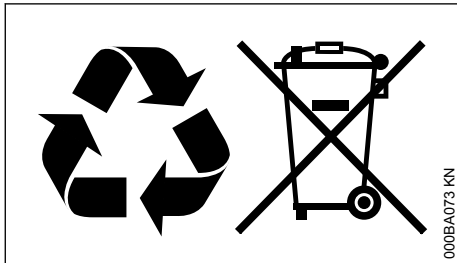

- ▶ Take STIHL products including packaging to a suitable collection point for recycling in accordance with local regulations.
- ▶ Do not dispose with domestic waste.

21 EC Declaration of Conformity

ANDREAS STIHL AG & Co. KG
Badstr. 115
D-71336 Waiblingen
Germany

declares under its sole responsibility that

Designation: KombiTool edger
Make: STIHL
Series: FCS-KM

Serial identification number: 4180

conforms to the relevant provisions of Directive 2006/42/EC and has been developed and manufactured in compliance with the following standards in the versions valid on the date of production:

EN ISO 12100 (in conjunction with the listed KM- and FR- tools)

EN ISO 12100, EN 60335-1, EN 50636-2-92 (in conjunction with the specified KMA tools).

Technical documents deposited at:

ANDREAS STIHL AG & Co. KG
Produktzulassung

The year of manufacture is specified on the power tool.

Waiblingen, 2022-08-01

ANDREAS STIHL AG & Co. KG

pp



Robert Olma, Vice President, Regulatory Affairs & Global Governmental Relations

CE

22 UKCA Declaration of Conformity

ANDREAS STIHL AG & Co. KG
Badstr. 115
D-71336 Waiblingen

Germany

declares under its sole responsibility that

Designation: KombiTool edger
Make: STIHL
Series: FCS-KM
Serial identification number: 4180

conforms to the relevant provisions of the UK Supply of Machinery (Safety) Regulations 2008 and has been manufactured in compliance with the following standards in the versions valid on the date of production:

EN ISO 12100 (in conjunction with the listed KM- and FR- tools)

EN ISO 12100, EN 60335-1, EN 50636-2-92 (in conjunction with the specified KMA tools).

Technical documents deposited at:

ANDREAS STIHL AG & Co. KG

The year of manufacture is indicated on the power tool.

Waiblingen, 2022-08-01

ANDREAS STIHL AG & Co. KG

pp



Robert Olma, Vice President, Regulatory Affairs
& Global Governmental Relations

**UK
CA**

23 Addresses

www.stihl.com

www.stihl.com



0458-472-0121-E



0458-472-0121-E